



Westruther

LAPASTORALE II (AKA Westruther)

ARCHITECTURAL DESIGN REQUIREMENTS

**ARCHITECTURAL
DESIGN REQUIREMENTS**

OCTOBER 2014

PREPARED BY:

ZKA Architecture

Reviewed and Updated March 2021

Pedri Lotz Architects

Westruther: AKA La Pastorale II

Reviewed and Updated-BY:

NOTE: pictures only shows elements of the architecture and must be read together with rest of architectural requirement

CONTENTS

1. Introduction
2. Overview of requirements
3. Build Form
4. Building line and setback requirements
5. Roofs
6. Walls
7. Windows and doors
8. Boundary walls
9. External balustrading
10. Driveways
11. Gates
12. Burglar bars
13. Antennae
14. Post Boxes
15. Street numbers
16. Landscaping

 initial here

Westruther: AKA La Pastorale II

17. General requirements

18. Building plan submission

19. Contractors

20. Contractor Access Control

21. Letter of compliance

 initial here

Westruther: AKA La Pastorale II

1. INTRODUCTION

The guidelines have been carefully developed so as to establish a timeless and collective architectural identity throughout the Estate without inhibiting the individual's creativity and style. The elements that form the essence of the style and the control of these elements are explained in this document.

The control elements are, amongst other things; the covering, pitch and colour of the roofs; exterior paint colours; the street and environmental interfaces; the appearances of the windows and relationship between buildings. By controlling these elements, the full potential will be realized as it is being developed, and will in turn, grow the investment that homeowners have made in their property. Specifically excluded elements are listed to prevent drastic style clashes.

Design principles have been established with the intention to create compatibility of Architectural styles rather than repetition.

To encourage a variety within the constraints of these requirements, interpretation and flexibility is vitally important to achieve a harmonious aesthetically pleasing development character without being excessively prescriptive and without eliminating freedom of choice.

All building designs are to be presented to the Architectural Review Committee or Control Architect for approval prior to submission to Council. The procedure and requirements are set out under **Building Plan Submissions**. **In respect of the interpretation of these guidelines, the decision of the Architectural Review Committee is final and binding.**

These guidelines are subject to change from time to time only as and when approved by Westruther Home Owners Association (WESTRUTHER HOA) and the Local Authority.

 initial here

Westruther: AKA La Pastorale II

Waivers to plans

The control Architect and/or HOA reserve the right to approve specific waivers in terms of these guidelines should Architectural merit be identified. Should any waivers be granted it will not set a precedent for future plan submissions in any way whatsoever.



Representation of typical style. Note cladding not allowed and roof pitch height limitations

○ initial here

Westruther: AKA La Pastorale II

2. Overview of REQUIREMENTS

- 2.1 Building time limit: Construction of houses must commence within 36 months of the date of transfer of the erf and is to be completed within 48 months of the date of transfer of the erf. Penalties for non-compliance as per the WESTRUTHER HOA.
- 2.2 Only one dwelling will be permitted per site.
- 2.3 An outbuilding no larger than 15% of the erf area will be allowed. (Outbuildings include freestanding garage, storeroom, maids' quarters, pool house, etc.)
- 2.4 The maximum coverage will be 60% of the individual ERF area.
- 2.5 The maximum Bulk or floor factor will be 70% of the total ERF area (including all covered areas).
- 2.6 The minimum area of the house, including the area of the garage, covered verandas and first floor will be 200m².
- 2.7 A maximum of 85% of the total ground floor plan area can be double storey (to avoid large block structures). Patios and pergola roofs may be included in this calculation.
- 2.8 Height restriction is 7.5m measured vertically from the Natural Ground Floor level prior to construction of the dwelling.
- 2.9 Main roof pitch allowed: 200 - 250 (degrees) only.

3. BUILD FORM

- 3.1 Dwellings are to be positioned in such a way that they make maximum use of the Northern sun and create sheltered areas away from the southern winds.
- 3.2 Building designs must follow the natural contour of the land. On sloped properties the house and/or patio finished floor level can be raised a maximum of 900mm above the natural ground level or must be stepped with planter or lower patio areas to break retaining wall structures (SKETCH 02).
- 3.3 Dwellings must be placed parallel or perpendicular to the street.
- 3.4 The main roof structure of the dwelling must have a double-pitched hipped roof with no gable ends. Flat concrete roofs, with 13mm crushed brown stone finish, can be used around pitched roofs and to link buildings.
- 3.5 The street elevation must be articulated with a lean-to roof, veranda structure, pergola and/or build "werf" wall of max 900mm high. These structures must be at least 6.0m wide (facing the street) (SKETCH 03).

 initial here

Westruther: AKA La Pastorale II

- 3.6 No portion of the built structure will be higher than 7.5m above the point on the natural surface of the ground, vertically below it. Contours to be indicated on all plan submissions (SKETCH 02).
- 3.7 Overlooking features onto neighbouring properties will be restricted (balconies and windows).
- 3.8 Balconies will be allowed to face the street, perimeter fence and public open areas but the side elevations within 3.5m of neighbouring properties must be screened from neighbouring properties with a 1.8m high screen wall (brickwork or hardwood screens). No other screen walls will be allowed
- 3.9 Windows on first floor levels, facing neighbouring properties: Existing houses and privacy will be considered & respected when scrutinizing plans. New designs must allow for maximum privacy. Larger windows must be fixed (no openable sections below 1.8m) and sandblasted.

Exclusions

- 3.10 Tuscan or Mediterranean reproductions, Decorative Victorian or Cape Dutch reproductions, Gable ends, Flat roofs without parapets

 initial here

Westruther: AKA La Pastorale II

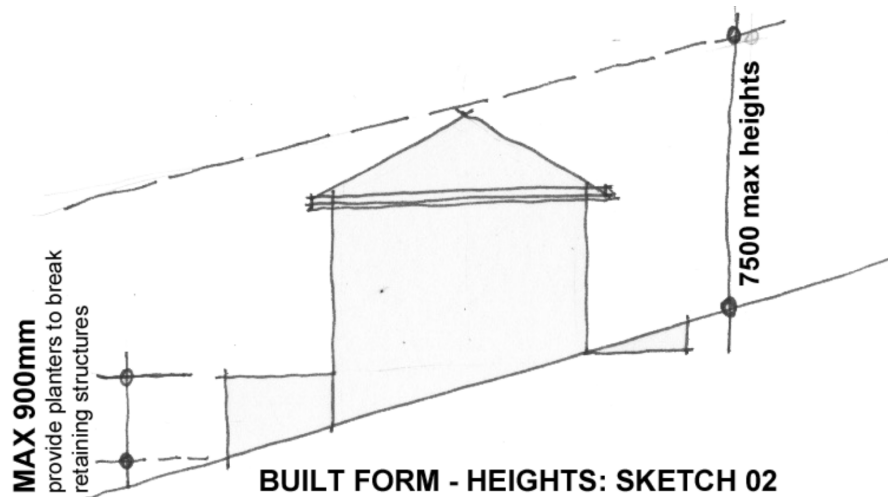

4. BUILDING LINE AND SETBACK REQUIREMENTS (see sketch 01)

Street building lines:

4.1 Garage: 4m

4.2 Dwellings: 2.5m for single storey and 4m for double storey.

4.3 A portion of the building can be at 2m from the street boundary. This portion can be a maximum of 15% of a street boundary length. If the street boundary is 22m you will be allowed 3,3m of the house on the 2m line.

4.4 Balconies (without roof structures): 2,5m

4.5 Ground floor pergolas, lean-to roofs, veranda structures: 1.5m

○ initial here

Westruther: AKA La Pastorale II

Common boundaries:

- 4.6 Garage: 1m for pitched roofs with maximum wall plate height of 3.5m. 0m for flat roofs with maximum dimensions of 3.5m high x 7.5m deep.
- 4.7 Single storey with a maximum wallplate height of 3.5m: 1.5m
- 4.8 Double storey: 2m
- 4.9 Pergolas, veranda structures: 1.0m (these structures may not be enclosed)

Private open space:

- 4.10 Single and double storey: 1.5m
- 4.11 Pergolas, veranda structures, patios: 1.0m (these structures may not be enclosed)
- 4.12 La Pastorale perimeter fence:
- 4.13 No structure will be allowed within 2m of perimeter fence

Also see "Build Form" for window and balcony requirements on common boundary lines

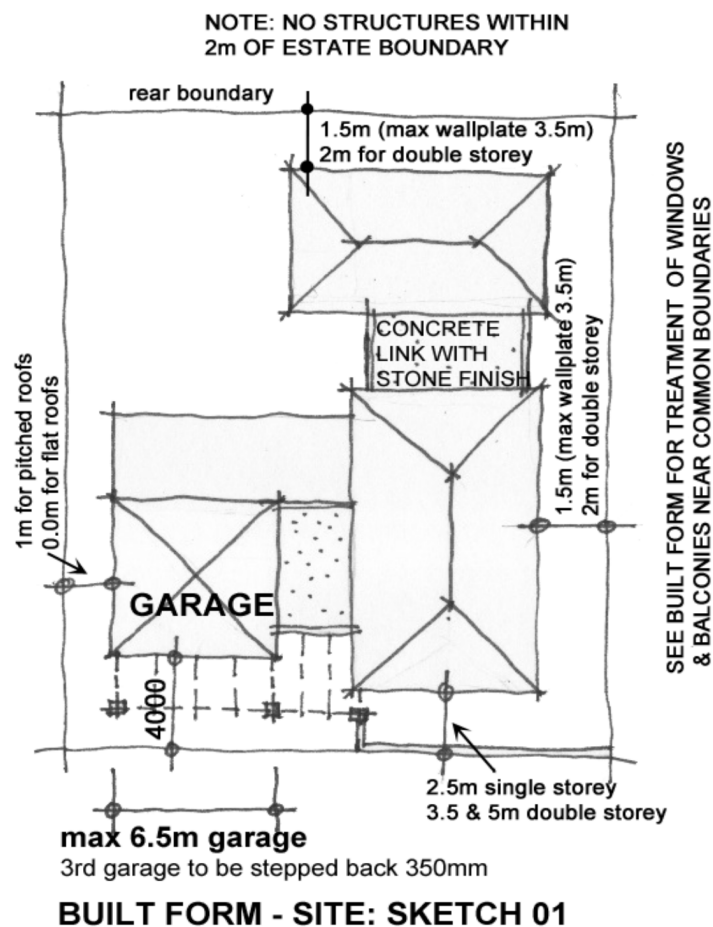

○ initial here

Westruther: AKA La Pastorale II

5. ROOFS

- 5.1 The main form must have a double pitched hipped roof of 20° - 25°. Different roof pitches cannot be used together.
- 5.2 “Dutch gable” details will be allowed on hipped roofs.
- 5.3 No mono pitch roofs, or differently pitched roofs will be allowed over a main form.
- 5.4 Gable ends: Can only be used to emphasise an element of the architecture. This can be a maximum of 3m wide with the same pitch as the main roof.
- 5.5 Single storey pitched roofs must have a minimum wall plate height of 3m (SKETCH 03).
- 5.6
- 5.7 Pitched roof structure may have a maximum of 350mm overhang/eave.
- 5.8 Roofs longer than 13m (measured from fascia to fascia line) must be split to break elevation lines. Flat concrete linking structures or min 800mm projecting roof structures can be used - (SKETCH 03 & 04).
- 5.9 Flat roofs: Maximum of 40% of bulk (floor factor). Must be concrete and can be used around pitched roofs and to link buildings. Provide 13mm crushed brown stone finish.
- 5.10 Flat roof structure may not cut into a pitched roof and must be under the roof overhang.
- 5.11 Raised light wells on ridges will be allowed but will be viewed strictly according to rest of guidelines and architectural merit.
- 5.12 Roof lights or skylights fitted into pitched roofs must be at the same pitch and of the same colour as the roof material used. Maximum size of skylights 1200x900mm.
- 5.13 A lean-to or veranda roofs must have a 5° pitch with the same roof materials as the main form on build precast round concrete pillars, square brickwork plastered columns, a combination hereof or thick timber sections. Visible timber sections must be hardwood or painted. NO visible stained pine will be allowed. Ends of visible rafters must have a shaped or curved detail – (SKETCH 07).
- 5.14 The placement of solar panels, heat pumps and air-conditioning equipment must be taken into account when designing the dwelling and shown on submitted plans.

Materials and colours

- 5.15 Tiles: Coverland / Monier Elite concrete roof tile: Slate grey. Marley Roofing: Modern Rustic Slate.
- 5.16 Roof sheeting: Corrugated iron sheeting in pre-painted finish in shades of medium and dark grey only (no natural metal finishes).

 initial here

Westruther: AKA La Pastorale II

- 5.17 Roof sheeting must be non-reflective.
- 5.18 Natural dark grey slate tiles.

Exclusions

- 5.19 Thatched roofs.
- 5.20 Roof finishes and colours other than indicated above.
- 5.21 Perspex domed roofs or similar.
- 5.22 Prefabricated carport structures.
- 5.23 Unpainted and reflective metal sheeting.
- 5.24 wind-driven extractor fans
- 5.25 Multi-coloured finishes

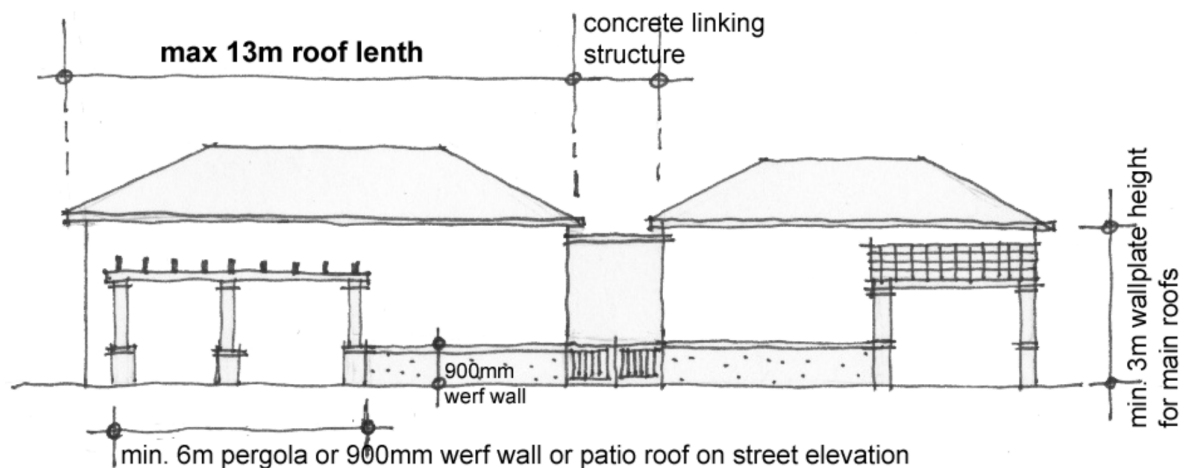

TYPICAL BUILT FORM: SKETCH 03

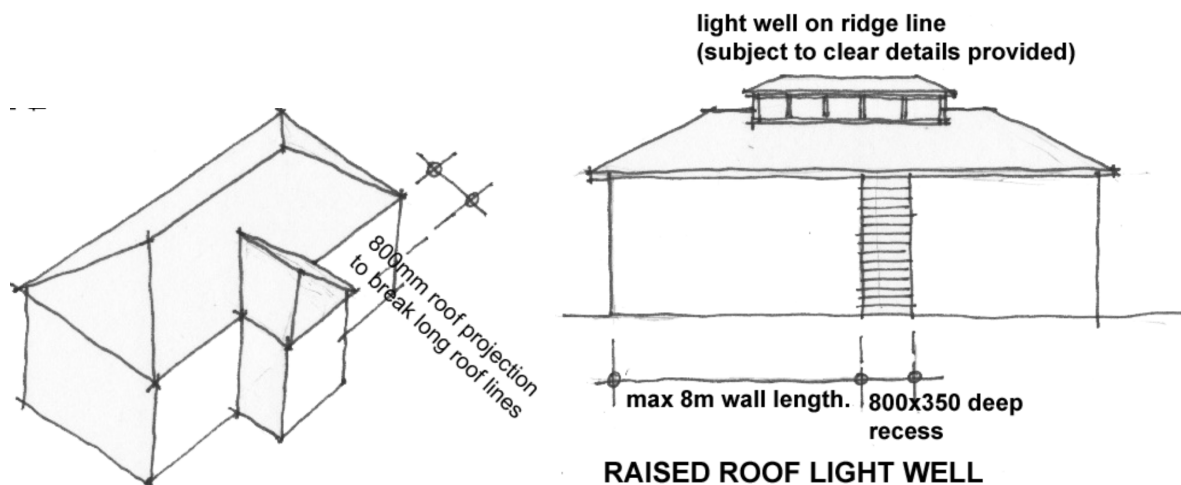

BUILD FORM - ROOF: SKETCH 04

RAISED ROOF LIGHT WELL & ELEVATION RECESS: SKETCH 05

○ initial here

Westruther: AKA La Pastorale II

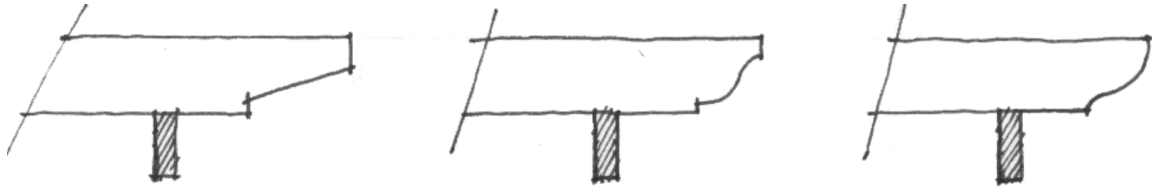

PERGOLA END TREATMENT / FINISH: SKETCH 07



NOTE: pictures only shows elements of the architecture and must be read together with rest of arch. Requirements

(GABLE ENDS LIMITED AND NO CLADDING ALLOWED)



NOTE: pictures only shows elements of the architecture and must be read together with rest of arch. Requirements

(no glass house structures, or bagged finishes allowed)

6. WALLS

6.1 General or predominant finish must be plaster but the following details will be allowed.

6.2 Cladding:

6.3 Hardwood, untreated or varnished, timber cladding can be used on very small, approved portions of the dwelling.

6.4 Walls on plan (or elevation) more than 8m in length and without any pergolas or veranda structures must have a minimum setback or recess of 350mm deep x 800mm

○ initial here

Westruther: AKA La Pastorale II

wide (SKETCH 5 & 6). Projecting fireplaces or functional projections to break the elevation walls will be allowed.

6.5 Garages on street elevations can only be 6500mm wide. A 350mm setback must be provided for wider/extra or longer garages – (SKETCH 11).

Colours – External Walls

6.6 Paint colours must be white or shades of white (brown/earthy or grey shades only).

The following paint colours must be used Plascon A1-1 White Orchid, etc. (as agreed by the HOA)

6.7 No shades of blue, yellow, pink or bright colours (yellow, blue, red etc.) will be allowed.

6.8 Only single paint colour can be used per dwelling.

Exclusions

6.9 Facebrick.

6.10 Bagged brickwork.

6.11 Two paint colours.

6.12 Large format and textured sheeting materials.

6.13 Stone or any tile cladding on elevations.

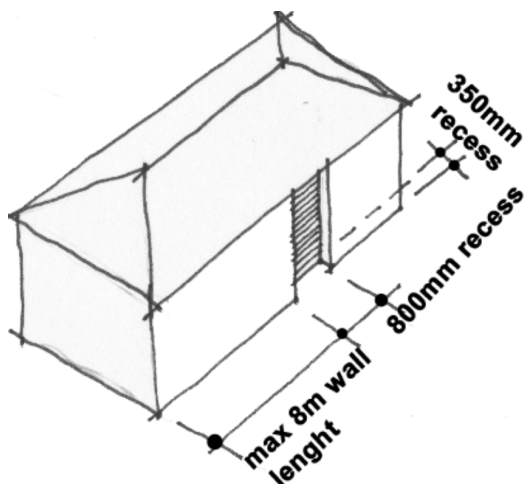

MAX WALL LENGTH: SKETCH 06

○ initial here

Westruther: AKA La Pastorale II

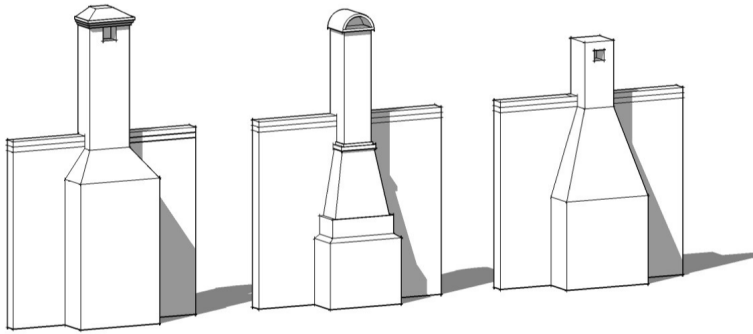

FIREPLACE & BRAAI TREATMENT



Allowed: columns, roof lines, windows and verandas.

NOTE: pictures only shows elements of the architecture and must be read together with rest of arch. requirements

○ initial here

Westruther: AKA La Pastorale II

7. WINDOWS & DOORS

The predominant shape of windows and doors must be vertical proportioned but with exclusions as listed below:

- 7.1 Horizontal proportioned toplight windows directly above doors or lower level windows may be used (this must form a unit on elevation)
- 7.2 350mm maximum height x 1800mm minimum width horizontal windows will be considered as details on elevations.
- 7.3 Using windows and doors in a series or sliding/stacking doors behind verandas or pergolas may form larger openings.
- 7.4 Shutters: Timber shutters or aluminium sliding shutters or aluminium louvers will be required where after Architectural scrutiny this is considered appropriate to break or enhance elevations.
- 7.5 Entrance doors must either be recessed a minimum of 800mm into the structure or be provided with a veranda or pergola detail over the door.
- 7.6 Minimum brickwork wall size between windows and doors to be 460mm.
- 7.7 Windows and doors must line up or form a unit on double storey houses – (SKETCH 10).
- 7.8 Placing of windows must be kept simple and uniform. No randomly placed elements will be allowed - (SKETCH 10).
- 7.9 Also see “Build Form” for windows facing neighbouring properties. Existing buildings/privacy will always be considered when scrutinizing plans.

Colours & Finishes

Matt white and matt stone grey (Interpon D 25) powder coated aluminium and white painted timber or natural timber only. Timber sections to be similar to Swartland Cape Culture range of windows. (See <http://www.windoorsa.com/swartland/cape-culture>)

Only one window & door colour will be allowed per house. Natural wood finishes and aluminium cannot be used together. Front doors, gates, garage doors, windows and other doors to be the same colour and similar in design. Front door finish may vary should this be used as a feature but is subject to approval by Architectural scrutiny.

 initial here

Westruther: AKA La Pastorale II

All doors, including front doors and garage doors, must be kept simple in design and specified on plans. Only horizontal or vertical details and large glazed portions will be allowed. No angled, curved, carved or small pane details on doors will be allowed.

- a. No fibreglass or PVC windows and doors will be allowed.
- b. No small pane cottage window frames, glass bricks, concrete or "winblock type" windows will be allowed.
- c. No reflective or mirrored glass will be allowed.

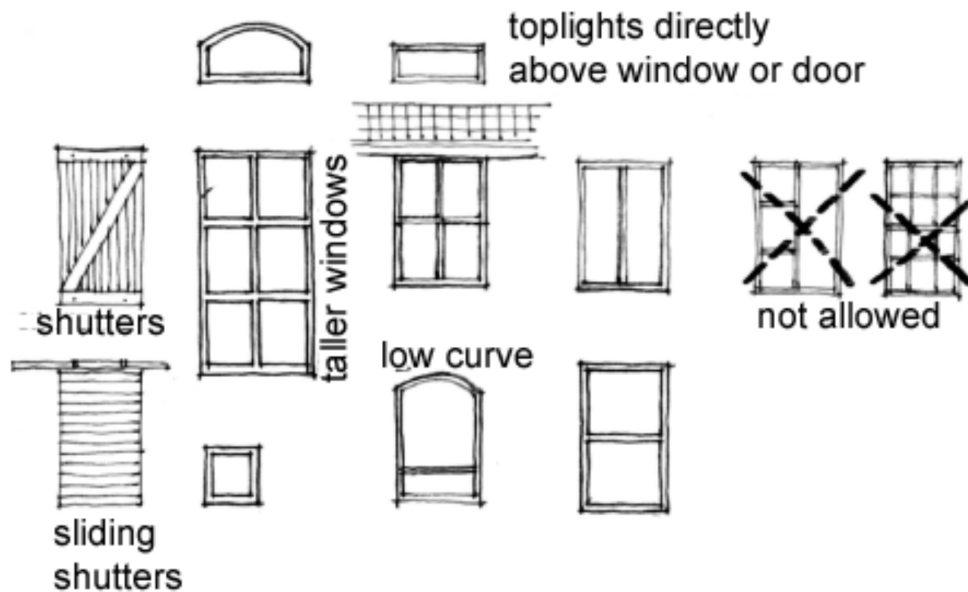

WINDOW STYLES AND PROPORTIONS: SKETCH 08

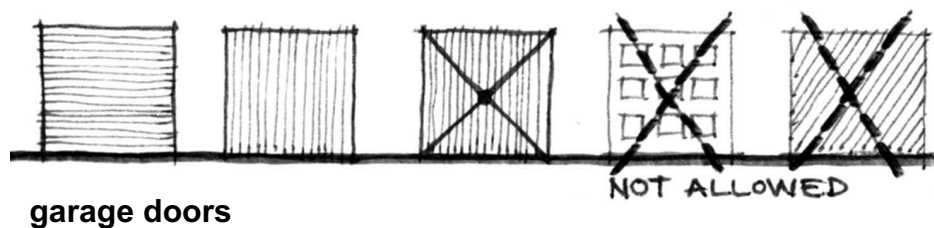

○ initial here

Westruther: AKA La Pastorale II

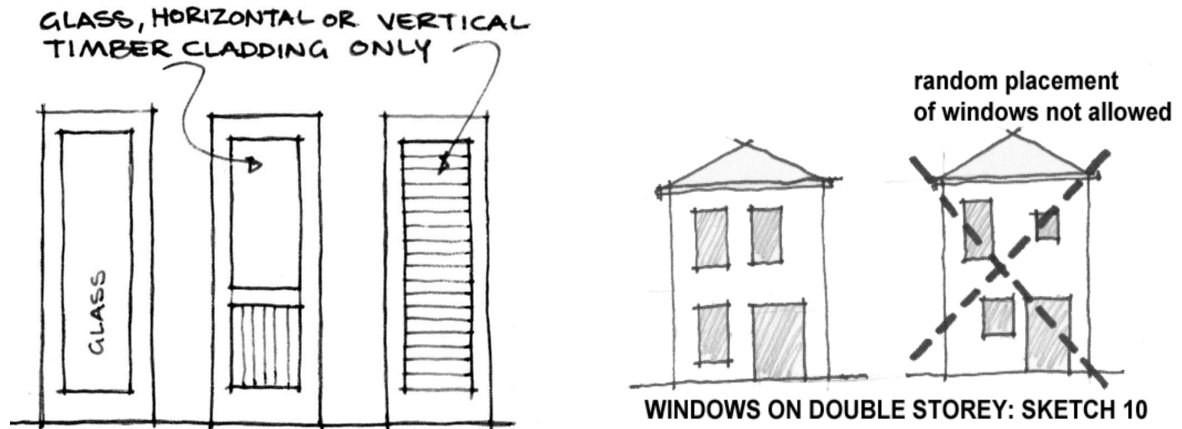

doors types



NOTE: pictures only shows elements of the architecture and must be read together with rest of arch. Requirements

(no bagged finishes allowed)

8. BOUNDARY WALLS

The following boundary wall options will be allowed and can be used where indicated under points 8.1 - 8.4.

- 8.1 Option 1: 900-1200mm high traditional farm style “werf” walling with curved top and pillars at large intervals as required.
- 8.2 Option 2: 1800mm high wall with 1900mm high columns at 2500mm centres. (*Take note of special conditions when used on street boundary and public open space)
- 8.3 Option 3: 1800mm high palisade fencing with 1900mm high columns at 2500mm centres. Provide 230mm wide x 400mm high wall between columns. Palisade fencing cannot be bulky and with a maximum of 20x20 galvanised steel bars. Provide a dark grey paint finish.

○ initial here

Westruther: AKA La Pastorale II

8.4 Option 4: 1800mm high solid 140mm or 190mm thick build wall. No columns required other than per Council regulations. Cannot be visible from the street.

8.5 8.1. Walls facing street boundaries:

8.6 Dwellings with entertainment and living spaces to rear or away from street view can only use option 1 or 3.

8.7 Dwellings with living spaces exposed towards the street can use option 1, 2* or 3.

8.8 *With option 2 at least 40% of the total street boundary length must be palisade fencing or have a 1.5m setback from the street boundary

Wall Facing Private pen spaces

Only options 1, 2* or 3 can be used.

8.9 *With option 2 at least 30% of total boundary length must be palisade fencing

Walls Between Neighbours

8.10 Any of the options 1-4 can be used but option 4 may not be visible from the street.

8.11 Kitchens, staff accommodation and washing yards must be screened from the neighbouring properties using options 2 or 4.

8.12 Brickwork between columns must be 190mm or 230mm thick and centrally positioned.

8.13 Columns must be 400x400mm or 460x460mm and at 2500mm centres.

8.14 Top of walls and columns to be finished with a 70mm wide plaster band and pyramid, round or square shaped capping.

8.15 Boundary walls must be plastered and painted. Clay R.O.K brickwork may be bagged but must be presented for Architectural scrutiny approval prior to construction.

8.16 No precast walling, vibracrete or similar, will be allowed.

 initial here

Westruther: AKA La Pastorale II

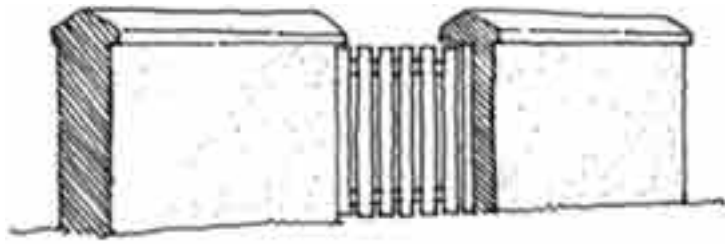

"WERF WALL"

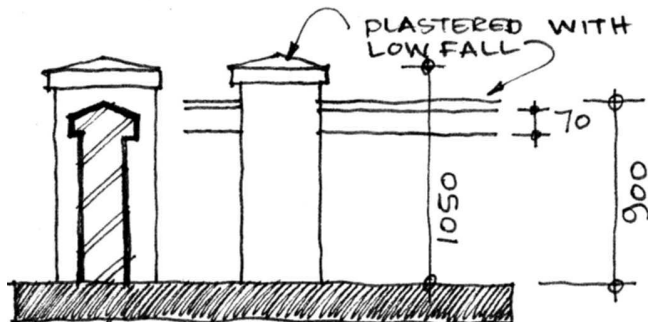

"WERF WALL"



9. EXTERNAL BALUSTRADING (sketch 09)

- 9.1 Galvanized and painted steel in dark grey finish. Railing: 50mm \varnothing steel or 96x44 hardwood timber mounted to top.
- 9.2 Steel sections:
- 9.3 Framework: Width = 50 to 80mm. Thickness 5 to 25mm
- 9.4 Infill sections: 5 to 12mm thick flat sections. 12mm \varnothing steel rods.
- 9.5 800mm high solid build wall with handrail over
- 9.6 Alternative wrought iron designs will be considered with submission of detailed drawings. Designs should be simple and fit in with the Architectural style.
- 9.7 Exclusions

○ initial here

Westruther: AKA La Pastorale II

- 9.8 Stainless steel framework or sections.
- 9.9 Steel and aluminium panelling in frames.
- 9.10 Heavy decorative wrought iron works.
- 9.11 Glazing in aluminium frames.
- 9.12 Decorative / elaborate designs.

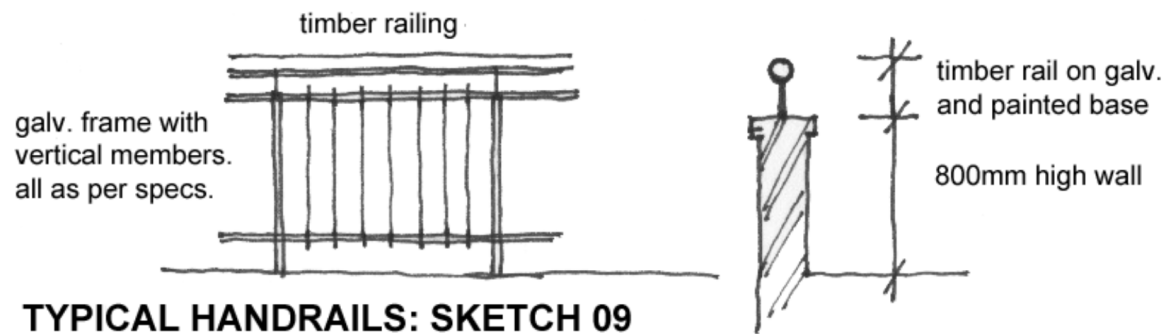

TYPICAL HANDRAILS: SKETCH 09

10. DRIVEWAYS

- 10.1 Driveways to be paved with maximum 13mm crushed Worcester brown exposed aggregate concrete pavers or in-situ cast concrete driveways with expansion joints (as per Lavarge Artevia).
- 10.2 Neatly paved, red ROK brickwork may be used.
- 10.3 A frame or border of 220mm wide with 110x110 grey/charcoal concrete cobblestone or De Hoop red clay pavers can be used.
- 10.4 Driveways can be a maximum of 6.5m wide. Wider driveways must be split using a minimum of 800mm planted area between driveways – (SKETCH 11). Maximum allowable paved areas on curb line will be 13m in total.

Exclusions

- 10.5 Tarred surfaces, other cement products, printed & coloured concrete and other stone colours or sizes.

Westruther: AKA La Pastorale II

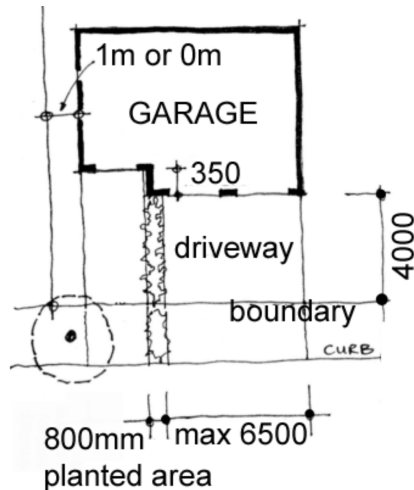

DRIVEWAY AND GARAGE: SKETCH 11

11. GATES (show designs on submitted plans)

11.1 Gate designs must be indicated on submitted drawings.

11.2 Gates must match lines of doors and of balustrading or palisade fencing.

11.3 Galvanised and painted steel framework with hardwood timber infill panels will be allowed.

11.4 Sheeting in any form (metal, plastic, fibre cement, etc.) is not permitted in the construction of gates.

12. BURGLAR BARS

12.1 Only internally mounted burglar bars will be considered. A simple grid pattern or horizontal lines, purpose made to suite the dimensions of the windows and to match window colour.

Exclusions

a. External burglar bars.

b. Externally visible Trellidor / Expanda-gate, Roller shutters or similar security systems.

c. Internal decorative wrought iron burglar bars.

13. ANTENNAE

13.1 No radio or television antennae or other similar equipment shall be located on the roof or street elevation of any building. Such equipment shall be located in the side or rear yard area or roof space.

14. POST BOXES

14.1 Post boxes will be provided at the entrance to Westruther.

○ initial here

Westruther: AKA La Pastorale II

15. STREET NUMBERS

15.1 Only matt black lettering in a plain font (i.e. Arial) will be allowed. Maximum height of lettering: 200mm

15.2 All lettering and numbering to be horizontally aligned.16. LANDSCAPING (indicate on submitted plans)

16.1 The verge/pavement areas must be landscaped and maintained by the owner. No grass to be planted on pavement/verge areas (grass only allowed within site boundaries).

16.2 13mm Worcester brown crushed stones may be used for landscaped areas visible from the street but can not cover more than 35% of visible area.

16.3 Red compacted earth with paved edging will be allowed when used together with small trees and scrubs. Detail plan to be submitted.

16.4 No large trees will be allowed on pavement/verge areas. Large trees planted anywhere on erf must be approved by HOA. The objective is not to obscure views.

16.5 Landscaping must add to the rural character of the estate and surrounding areas (Stellenbosch / Franschhoek heritage areas). Tropical varieties (palm trees, etc.) will not be allowed.

16.6 A landscape layout for areas visible from the street must be submitted for approval.

16.7 Landscaped areas visible from the street must be completed before the building deposit will be refunded.

 initial here

Westruther: AKA La Pastorale II

17. GENERAL REQUIREMENTS

- 17.1 All exposed plumbing must be screened from the street and plumbing from the first-floor levels must be in a duct hidden from view.
- 17.2 Solar geysers must be installed inside the roof space and cannot be visible externally. Solar panels must follow the pitch of the roof and may not be visible from the street.
- 17.3 Solar panels placed on flat or low-pitched roofs must be screened on all sides and may not be visible on any of the elevations.
- 17.4 Water storage tanks must be screened with brick walling or hardwood timber screens.
- 17.5 Cottages, granny flats, outbuildings and additions must match the character of the original main building. No “wendy houses” or any prefabricated structures will be allowed.
- 17.6 Temporary carports will not be allowed. Carports must match house design.
- 17.7 Fabric awnings are not allowed.
- 17.8 Air-conditioning units must be mounted at low level and screened from street and neighbouring properties.
- 17.9 The requirements of the Local Authority Town Planning scheme and the National Building Regulations shall apply to all.



Westruther: AKA La Pastorale II

NOTE: pictures only shows elements of the architecture and must be read together with rest of arch. Requirements. No cladding allowed.

18. BUILDING PLAN SUBMISSION

CLEAR NOTE TO BE ON ALL DRAWINGS

All Construction and finishes must comply with Westruther Architectural requirements and approved plans. Any changes must be confirmed in writing by the WHO.

- 18.1 Designs and building plans must be prepared by SACAP registered professionals: Pr.S.Arch.T or Pr.Arch.
- 18.2 Sketch plans and Council drawings to be submitted to the estate scrutiny architect for approval prior to submission to Council.
- 18.3 The estate architect will approve or comment on the plan submission within one week.
- 18.4 The aesthetic appearance and architectural character will be scrutinised for approval.

Submission Procedure:

- 18.5 18.1.5 Prior to the submission of any plans the Architectural scrutiny fee, as determined by the Westruther Homeowners Association (WHOA), must be paid to the estate architect.
- 18.6 The first draft of the plans must then be submitted via e-mail to the estate architect in PDF format.
- 18.7 Amendments or approval notices will be e-mailed
- 18.8 5 sets of the revised plans must be resubmitted for signature and approval stamps.
- 18.9 The attached LETTER OF COMPLIANCE must be completed and accompany these plans.
- 18.10 Before the plans will be released for Council submission a refundable Building Deposit of R50,000, must be paid to the WHOA account through the management agency.
- 18.11 A Non-Refundable Building Contribution Road Maintenance Levy of R 1 200.00 per month
- 18.12 A Non-Refundable Building Contribution Admin Levy of R 2 000.00 per month. Both of these payments will be added to the HO levy for the period of the build.

 initial here

Westruther: AKA La Pastorale II

18.13 One set of drawings will be kept for record purposes.

18.14 The architectural scrutiny fee includes a site inspection after completion of the house. The estate architect will provide the owner with a completion certificate if the house, boundary walls and all finishes comply with the approved drawings. Only then may the house be occupied. At this point the refundable building deposit will be refunded to the HO.

18.15 There should be no changes to the original approved and stamped drawings otherwise the certificate will not be issued, and occupation of the dwelling may not take place

Plans to include:

- a. a site plan with contour lines
- b. floor plans indicating the dwelling layout, boundary walls, landscaping, driveways, solar panels, gas bottles, etc.
- c. elevations with all finishes and colour choices
- d. sections indicating the height restrictions
- e. roof layout
- f. area of house and outbuildings, coverage and bulk calculations

Waivers to plans

The Estate Architect reserves the right to approve specific waivers in terms of these guidelines should Architectural merit be identified. Should any waivers be granted it will not set a precedent for future plan submissions in any way whatsoever.

NOTE: pictures only shows elements of the architecture and must be read together with rest of arch. requirements

 initial here

Westruther: AKA La Pastorale II

19. CONTRACTORS

Definitions:

HOA Member: All owner/purchaser of an erven within the Westruther estate

Owner: The legal purchaser of an Erf

Contractor: Sub-contractors, agent(s), workers or any other similar entity or person involved in any such building operations

Accountable: (Owner) Required to justify the actions or decisions of their contractor.

Responsible: (Contractor) Having an obligation to carry out the construction of a build and answerable to the accountable party (The Owner).

Bottom Erven*: Numbers -**15670, 15671, 15672, 15682, and 15681** will be referred to as the ***bottom Erven***.

Top Erven:** Numbers **15676, 15677, 15678, and 15679** will be referred to as the ****top erven****.

Erf 15684: A dedicated Estate communal park area.

Main Gate*:** On the NW aspect of the estate and leads onto Bach Street

Top Gate**:** On the eastern boundary and leads onto Telemann Street

Westruther Estate: Estate

OWNER TO MAKE ALL CONTRACTORS AWARE OF THESE RULES

19.1 Each property owner will be accountable for all activities of their Building Contractor and Sub-contractors (Contractor) while within the boundaries of Westruther.

19.2 Building work must be done according to the stamped and approved plans. The controlling architect and HOA must be consulted prior to any changes made.

19.3 A R1000 fine (or as amended from time to time) will be issued to the owner for any violation of the rules listed below. Fines must be paid before work can progress.

19.4 The Contractor or owner must make sure that the water meter is in order, tested to measure correctly, correctly connected and secured and submit the meter reading to the WESTRUTHER HOA before construction starts. It must be positioned in such a way as to prevent damage to it

19.5 The final water meter position must be outside the boundary wall on the pavement area and accessible at all times

19.6 The Contractor must provide a site toilet before any work may begin on site

 initial here

Westruther: AKA La Pastorale II

19.7

19.8 Wire netting of 1.8m high, covered with suitable plastic netting must be used around the building site to prevent unauthorised entry after hours and to minimise dust, plastic bags and papers etc. Owners will be fined for materials blown or strewn around the Estate or outside the boundaries of their properties.

19.9 Contractor's employees or sub-contractors will not be allowed to wonder around the Estate All contractors must remain in their area of work. Rest areas should be provided on the building site. Contractors will not be allowed to rest, eat lunch or roam around on unoccupied erven or the communal areas within the estate.

19.10 Roads should be kept clean and clear of building materials at all times. The removal of mud or building rubble from the roads must be conducted at the end of each working day.

19.11 Only rigid trucks will be allowed on the estate, which means no "horse and trailer"

Building hours:

1. Mondays to Fridays: 7am to 6pm.
2. Saturdays: 7h30am – 4pm (no machinery or noisy work will be allowed to operate after 12noon).
3. No building work on Sundays, Christmas day and Good Friday. Public holidays are treated as Saturdays.
4. No building work during the normal yearend builder's holidays, which is from +-15 December to +-9 January of the next year.

 initial here

Westruther: AKA La Pastorale II

20. Contractors Access Control Policy

The Westruther estate consists of 14 erven, currently six have so far been constructed, these are Erf numbers 15673, 15674, 15675, Erf 15680 Erf 15672 and 15683 all of which are occupied as of March 2021

Access control for all contractors and their sub-contractors during the construction of the bottom erven*, will be managed through the main gate***.

Access Control for construction of the top erven will be through the ** top gate**** up to the point where erf 15676 has been sold.

Construction Contractor Protocols

- 20.1 The owner will be accountable for the access control to the Estate of all his contractors.
- 20.2 The main contractor will be responsible for the access control to the Estate of all his contractors and sub-contractors.
- 20.3 The Contractor or his foreman will be responsible for opening the gate for their employees to enter or exit the Estate. Fines will be issued if employees tamper with the gate, access control or security fence in any way.
- 20.4 Allowing unauthorised access to third parties either directly or through tailgating is unacceptable and will be dealt with accordingly. The gates are covered by CCTV 24/7 and all movement is recorded.
- 20.5 Entering the estate outside of the listed working hours is not permitted.
- 20.6 All contractor vehicles entering through the main gate* must stop short, next to the dedicated turn around point on the left as they approach the gate. At this point they will communicate with their main contractor and request access prior to approaching the gate.
- 20.7 All contractor vehicles will ensure that when in a waiting pattern as outside the main gate, they are sufficiently pulled over to the left-hand side of the road to allow free flow of authorised traffic. They are not to block the road at any point and ensure there is free passage for residents and other authorised users.
- 20.8 Residents must be given right of way at all times.
- 20.9 There will be no sounding of horns in an attempt to gain access to the estate.
- 20.10 If a contractor has a need to block the road for a limited time period due to construction constraints, pouring concrete, or heavy lifting for example, they must give 24 hours' notice to the HOA so alternative access control can be used at this time. Where possible this must be avoided or kept to an absolute minimum. This disruption to normal access control is to be communicated to all HOA members by the Owner.
- 20.11 There will be no parking on the roads, the contractor will provide off road parking in order to keep access and egress safe and unrestricted to residents and their guests. This will require agreement with the owners of vacant Erfs. A suitable hard standing should be prepared for off-road parking during periods of rain.

 initial here

Westruther: AKA La Pastorale II

- 20.12 If the main gate* is temporarily out of use the contractor will place a sign at the junction with Paradyskloof road informing people to use the top gate**. This must be managed by the contractor and the sign removed once the obstruction to the gate is cleared.
- 20.13 Any damage caused to the gate or fence by the contractor that compromises the security of the estate must be rectified immediately by the contractor. The cost of this will be levied against the HO. At no point must the residents be exposed to greater risk in the event of damage caused by the contractor.
- 20.14 An owner whose contractor violates the above rules, will be subject to a fine of R1,000 for each indiscretion by the HOA in its own favour, on condition that:
- a. the infringement is duly recorded in writing on the day of the infringement and signed both by a representative of the HOA and by the infringer, or a person in charge of the infringer, or an independent witness of the event, or
 - b. within 7 (seven) days of reporting of the incident in writing to the Association, if photographic or other hard evidence of the infringement is produced, and
 - c. written notification of the infringement is sent to the Purchaser within 10 (ten) days thereof

 initial here

Westruther: AKA La Pastorale II

21. LETTER OF COMPLIANCE: Erf.....Westruther, Stellenbosch

Please complete and submit with building plans. Delete items not applicable

I/we the registered / new owner(s) of Erf hereby confirm/agree to the following:

I/we have received a copy of the Westruther Architectural Requirements (revised) and the Westruther Home Owners Constitution (including all the revisions) and agree to the rules and regulations as stated therein

1. I/we are aware that the WESTRUTHER HOA and the Controlling Architect has rights to enforce penalties/fines and/or remedial action
2. I/we agree to pay the required accounts (levies, water and sewer, penalties and fines etc.) as set out or requested by the WESTRUTHER HOA and all legal fees incurred by the WESTRUTHER HOA for the collection of outstanding payments
3. I/we will ensure that all payments to the WESTRUTHER HOA and estimates of levies and services have been paid prior to permission for the transfer of this property will be given by the WESTRUTHER HOA
4. I/we will inform the WESTRUTHER HOA of the date I/we take occupation of the property
5. I/we agree to adhere to the arrangements regarding the issuing and use of remotes and access control for operating the entrance gate
6. I/we will construct and/or alter the dwelling on this property as per the Westruther Architectural Requirements and approved building plans, including all details and finishes
7. I/we will submit all changes of the approved plans to the controlling architect for approval prior to commencing construction
8. I/we will submit all external finishes to the controlling architect for approval prior to commencing these
9. When repainting the dwelling I/we will submit all external finishes to the controlling architect for approval prior to commencing these
10. I/we will deposit the required building deposit into the account of WESTRUTHER HOA before permission will be granted for commencing construction
11. I/we agree that the building deposit will only be refunded and the levy reduced to the

 initial here

Westruther: AKA La Pastorale II

normal levy, once all have been completed as required by the controlling architect and after issuing of the completion certificate

12. I/we agree that newly constructed dwelling will only be occupied once I receive permission from the controlling architect

13. I/we agree that only rigid trucks, including furniture removal trucks, may enter the premises

NameDesignation.....

Address.....

Telephone.....Fax.....

Cell phone.....Email.....

Signed: _____ At: _____ Date: _____

I/we hereby agree to comply with all the rules of the Westruther Home Owners Association.

 initial here